



2003 - 12/2006

## MITSUBISHI OUTLANDER

Cat. No. Y/021

e20

e20\*94/20\*0880\*00

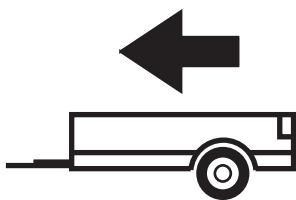

1500Kg

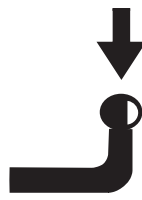

75Kg

**D** = 8,66kN

**D (kN) =**



MAX kg

x

MAX kg

x 0,00981



MAX kg

+

MAX kg

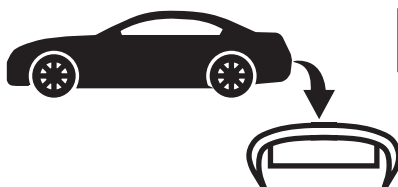

**IMIOLA HAK-POL**

96-111 KOWIESY, CHOJNATA 23A, POLAND

tel. +48 46 831 73 31, fax +48 831 74 29

e-mail: office@imiola.pl, www.imiola.pl

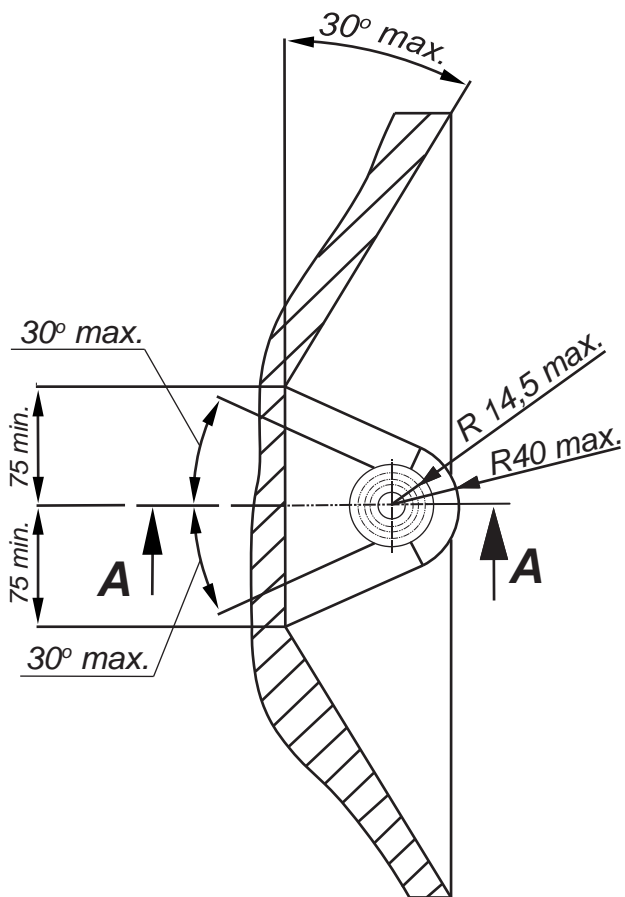

### PRZEKRÓJ A-A

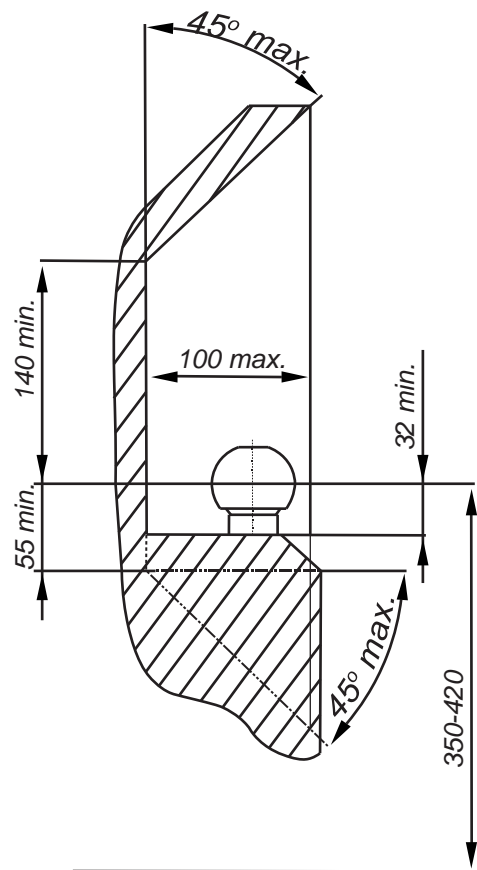

**PL** Należy zagwarantować przestrzeń swobodną według załącznika VII, rysunek 25a/b Regulaminu EKG ONZ 55.01 przy dopuszczalnym ciężarze całkowitym pojazdu.

**F** L'espace libre doit être garanti conformément à l'annexe VII, illustration de la réglementation 55.01 CE pour un poids total en charge autorisé du véhicule.

**GB** The clearance specified in appendix VII, diagram 25a/b of Regulation No. 55.01 UN EU must be guaranteed at laden weight of the vehicle.

**D** Der Freiraum nach Anhang VII, Abbildung 25a/b der Vorschriften 55.01 EG ist zu gewährleisten bei zulässigem Gesamtgewicht des Fahrzeuges.

Moment skręcający dla śrub i nakrętek (8.8) Torque settings for nuts and bolts (8.8)	
M8	25Nm
M10	55Nm
M12	85Nm
M14	135Nm
M16	195Nm

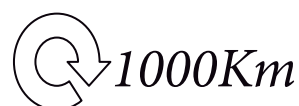

Śruba M10x35-8.8 ; Bolt  
Podkł. spręż. 10,2 ; Spring Washer  
Podkł. okr. 10,5 ; Plain Washer

Nakrętka M10 ; Nut  
Podkł. spręż. 10,2 ; Spring Washer  
Podkł. okr. 10,5 ; Plain Washer

Śruba M10x1,25x35-8.8 ; Bolt  
Podkł. spręż. 10,2 ; Spring Washer  
Podkł. okr. 10,5 ; Plain Washer

Śruba M10x1,25x35-8.8 ; Bolt  
Podkł. spręż. 10,2 ; Spring Washer  
Podkł. okr. 10,5 ; Plain Washer







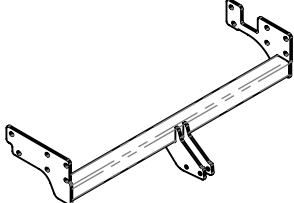
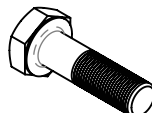
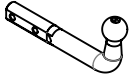

Śruba M10x1,25x35-8.8 ; Bolt  
Podkł. spręż. 10,2 ; Spring Washer  
Podkł. okr. 10,5 ; Plain Washer

Śruba M12x70-8.8 ; Bolt

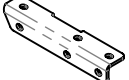
Nakrętka M12 ; Nut  
Podkł. spręż. 12,2 ; Spring Washer  
Podkł. okr. 13 ; Plain Washer

Śruba M10x1,25x35-8.8 ; Bolt  
Podkł. spręż. 10,2 ; Spring Washer  
Podkł. okr. 10,5 ; Plain Washer

Nakrętka M10 ; Nut  
Podkł. spręż. 10,2 ; Spring Washer  
Podkł. okr. 10,5 ; Plain Washer

	A	x1		M12x70	2
				M10x1,25x35	12
				M10x35	6
	B	x1		M12	2
				M10	6
	C	x1		13	2
				10,5	18
	D	x1		12,2	2
				10,2	18
	E	x1			
	F	x1			

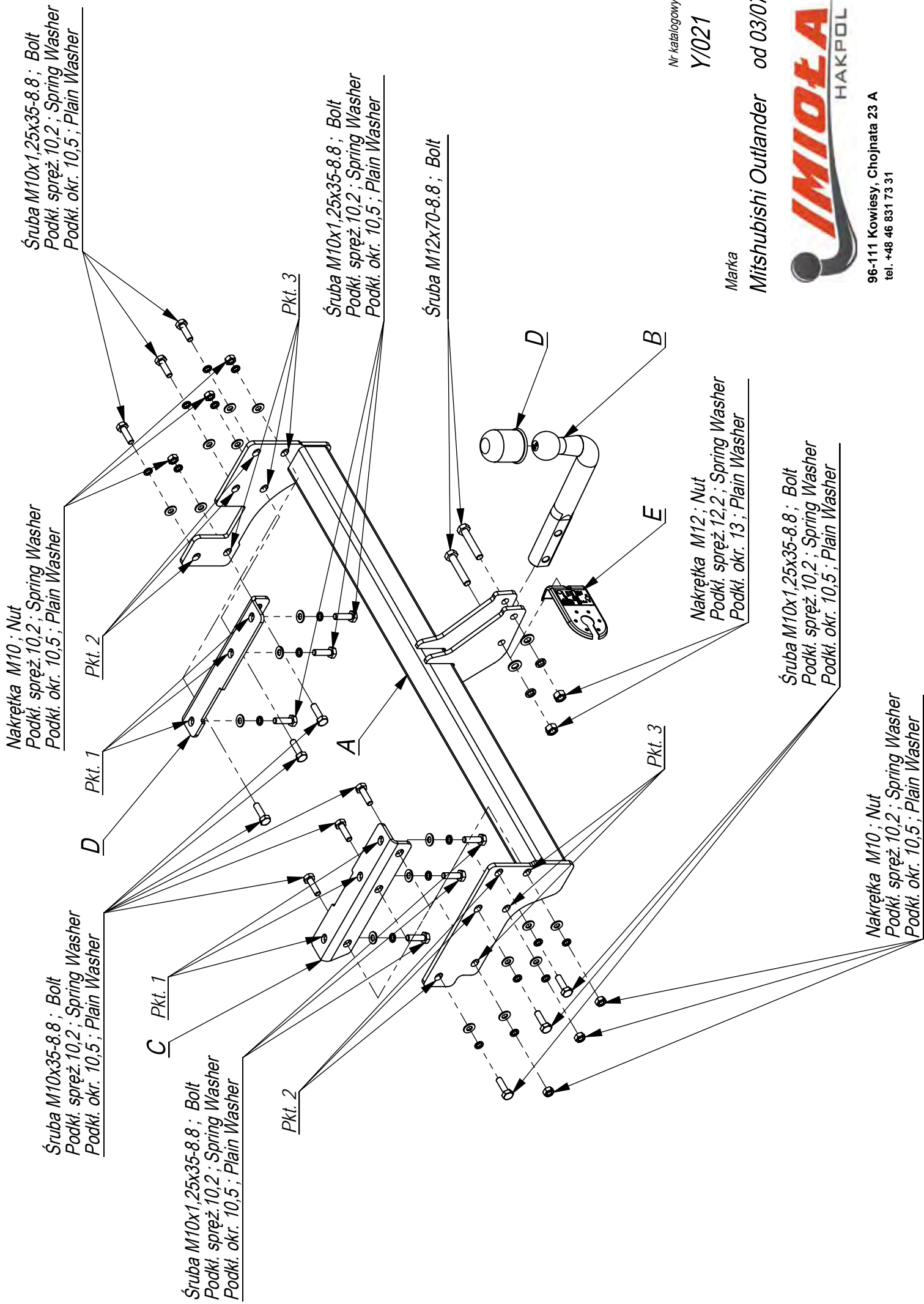

Nr katalogowy

Y/021

Marka

Mitsubishi Outlander od 03/07



96-111 Kowiesy, Chojnata 23 A  
tel. +48 46 831 73 31

- Opuścić tłumik z tylnego zawiesia.
- Udzielić technologiczne otwory z gwintami w podłużnicach.
- Od spodu lewej podłużnicy przyłożyć element zaczepu B tak, aby otwory (pkt 1) pokryły się z fabrycznymi nagwintowanymi otworami.  
Skręcić lekko śrubami M10x35x1,25.
- Do prawej podłużnicy przyłożyć element zaczepu C tak, aby otwory (pkt 4) pokryły się z fabrycznymi nagwintowanymi otworami. Skręcić lekko śrubami M10x35x1,25 (pkt 2 i 4).
- Belkę zaczepu A przykręcić do podłużnic śrubami M10x35x1,25 (pkt 2).
- Elementy zaczepu B i C przykręcić do belki zaczepu A śrubami M10x35 8.8 (pkt 5).
- Dokręcić wszystkie śruby z momentem wg tabeli.
- Założyć tłumik.
- Przykręcić kulę i blachę gniazda elektrycznego.
- Podłączyć instalację elektryczną.

- Lower the damper from the rear hanger.
- The threaded technological holes in the metal clamps make permeable.
- Put the element B of the bottom of the left metal clamp in this way, so the holes (point 1) agree with the technological threaded holes.  
Screw slightly with bolts M10x35x1,25 (point 1 and 2).
- Put the element C to the right metal clamp in this way, so the holes (point 4) agree with the technological threaded holes. Screw slightly with bolts M10x35x1,25 (point 2 and 4).
- Screw the main bar A to the metal clamps with bolts M10x35x1,25 (point 2).
- Screw the elements B and C to the main bar A with bolts M10x35 8.8 (point 5).
- Tighten all the bolts according to the torque setting- see the table.
- Assemble the damper.
- Fix the ball and electric plate.
- Connect the electric wires.

