



SEAT Altea, Leon
SEAT Altea XL
SEAT Toledo

05/2007 -
11/2006 -
2005 -

Cat. No. S/013

e20

e20*94/20*0755*00

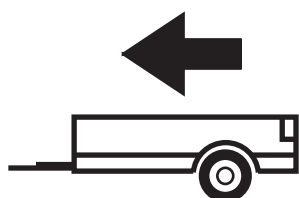

1600Kg

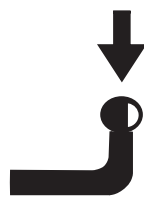

75Kg

D = 8,91kN

D (kN) =



MAX kg

x

MAX kg

x 0,00981



MAX kg

+

MAX kg



IMIOLA HAK-POL

96-111 KOWIESY, CHOJNATA 23A, POLAND

tel. +48 46 831 73 31, fax +48 831 74 29

e-mail: office@imiola.pl, www.imiola.pl

PRZEKRÓJ A-A

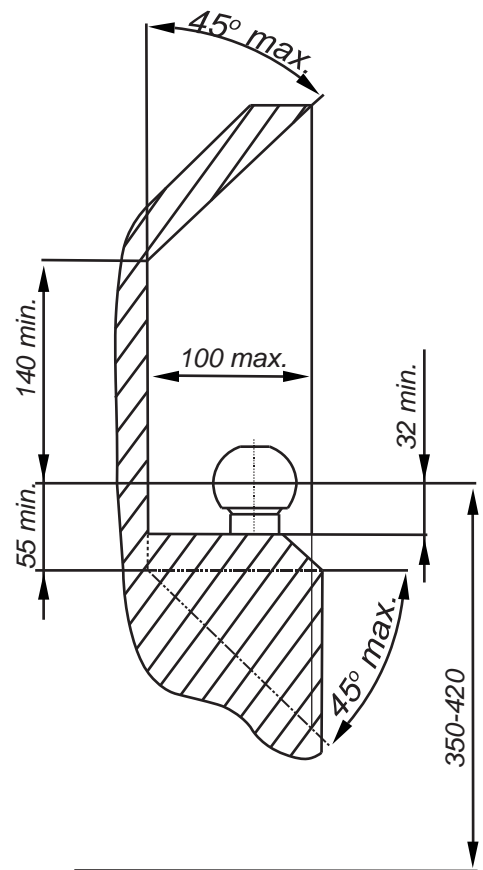
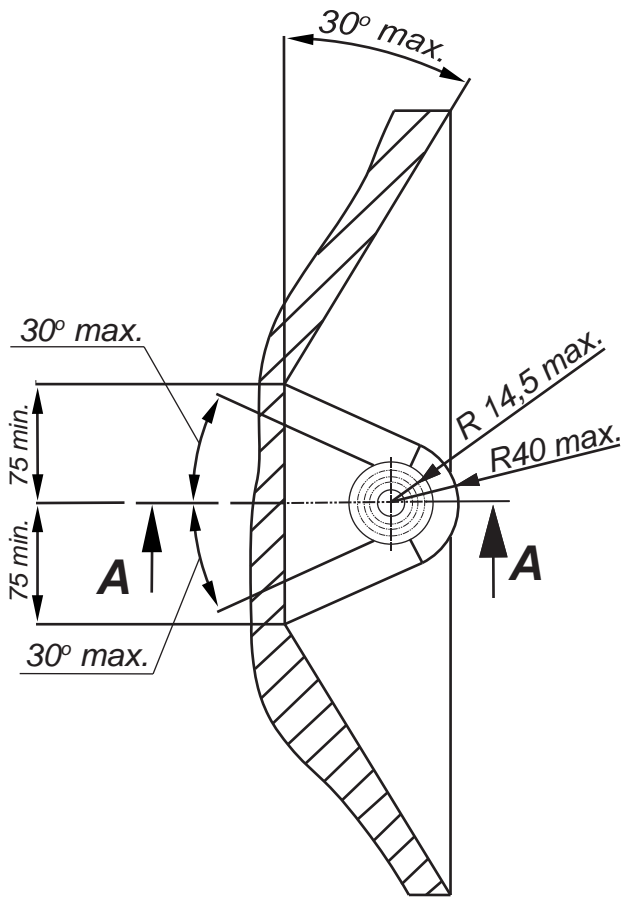

PL Należy zagwarantować przestrzeń swobodną według załącznika VII, rysunek 25a/b Regulaminu EKG ONZ 55.01 przy dopuszczalnym ciężarze całkowitym pojazdu.

GB The clearance specified in appendix VII, diagram 25a/b of Regulation No. 55.01 UN EU must be guaranteed at laden weight of the vehicle.

F L'espace libre doit être garanti conformément à l'annexe VII, illustration de la réglementation 55.01 CE pour un poids total en charge autorisé du véhicule.

D Der Freiraum nach Anhang VII, Abbildung 25a/b der Vorschriften 55.01 EG ist zu gew 25a/bahrleiten bei zulässigem Gesamtgewicht des Fahrzeuges.

Moment skręcający dla śrub i nakrętek (8.8) Torque settings for nuts and bolts (8.8)	
M8	25Nm
M10	55Nm
M12	85Nm
M14	135Nm
M16	195Nm

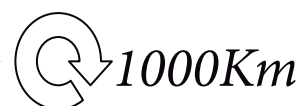

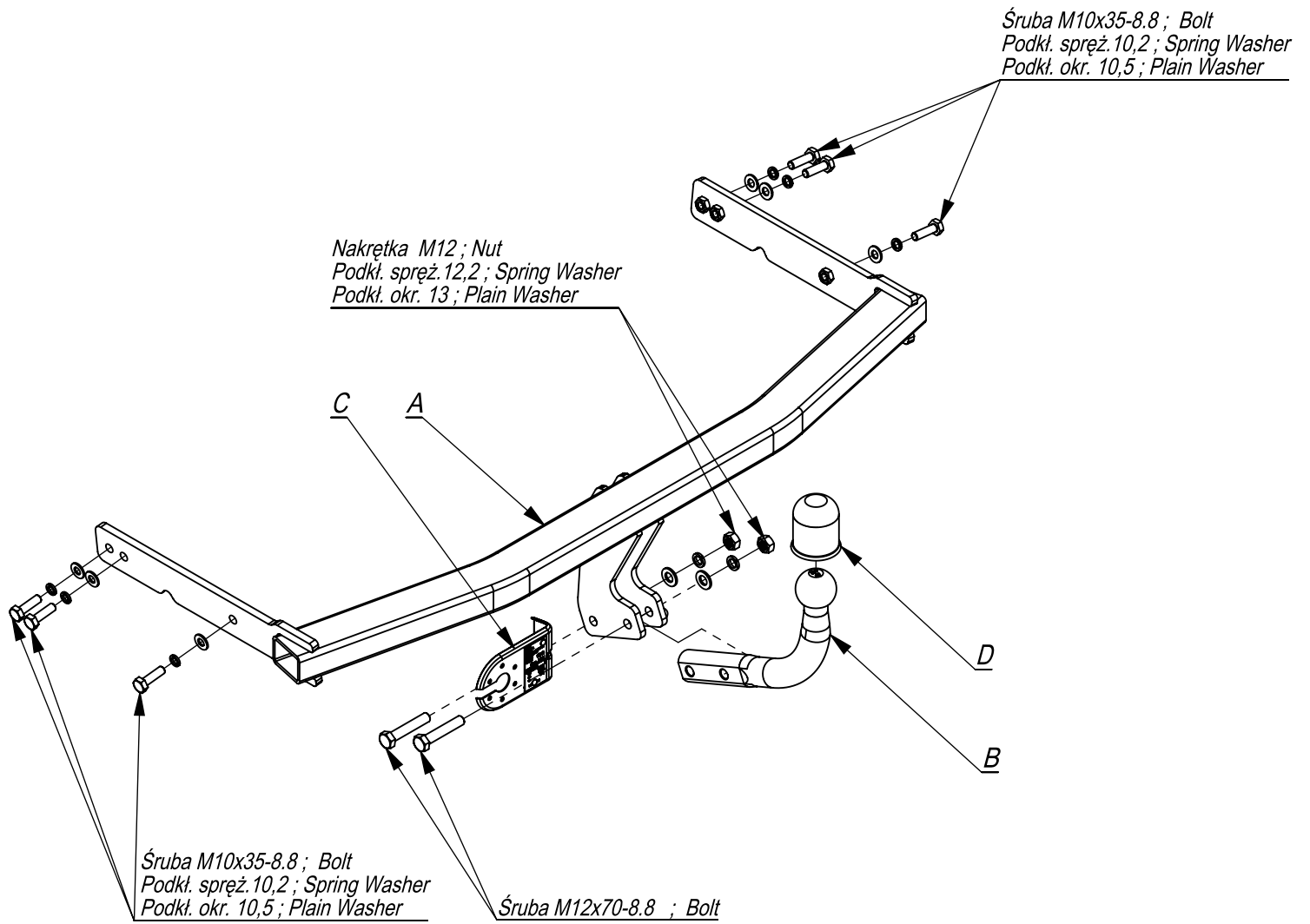

	A	x1		M12x70	2
				M10x35	4
	B	x1		M12	2
				13	2
	C	x1		10,5	4
				12,2	2
	D	x1		10,2	4

Śruba M10x35-8.8 ; Bolt
 Podki. spręż. 10,2 ; Spring Washer
 Podki. okr. 10,5 ; Plain Washer

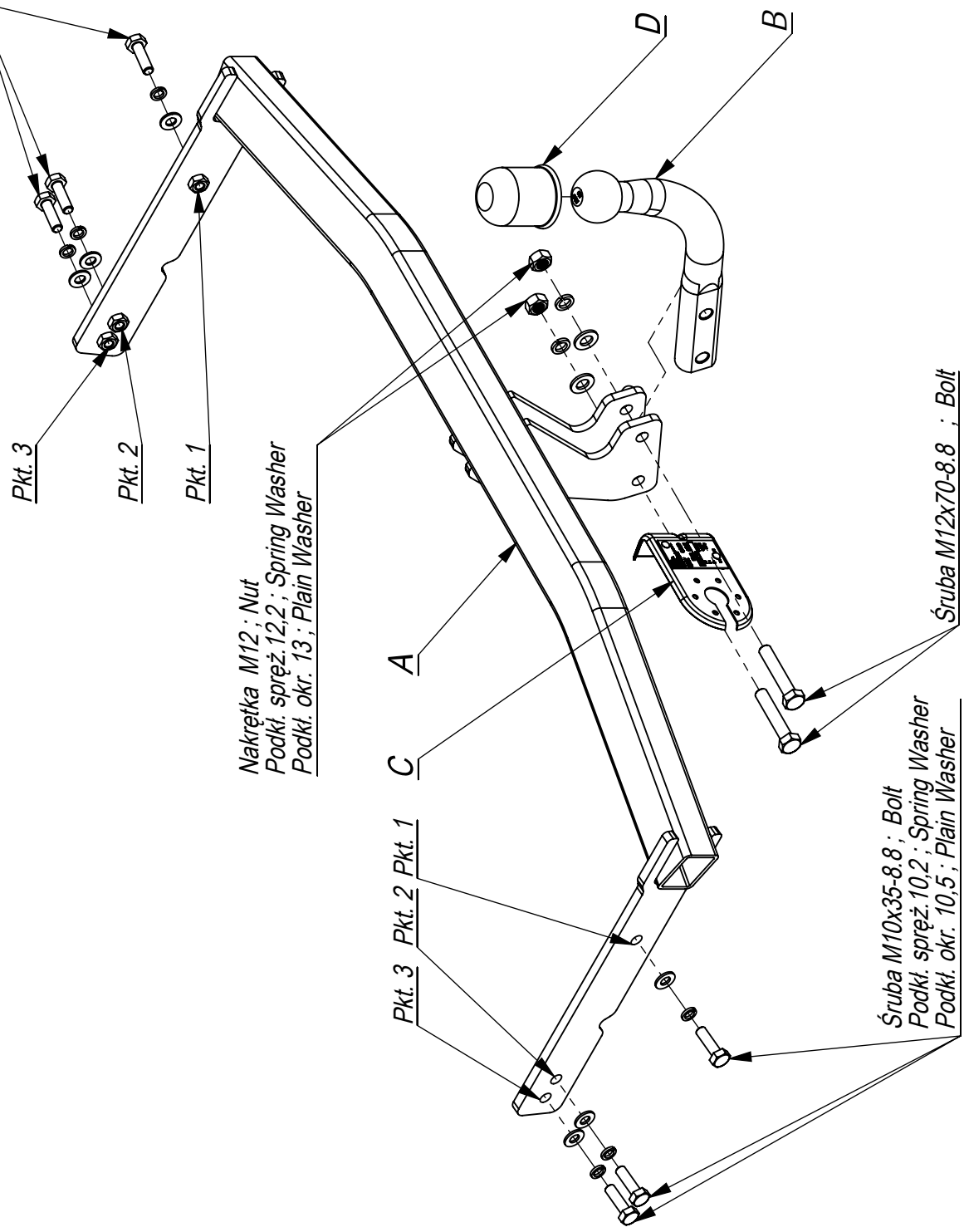

Nakrętka M12 ; Nut
 Podki. spręż. 12,2 ; Spring Washer
 Podki. okr. 13 ; Plain Washer

Śruba M10x35-8.8 ; Bolt
 Podki. spręż. 10,2 ; Spring Washer
 Podki. okr. 10,5 ; Plain Washer

Śruba M12x70-8.8 ; Bolt

Nr katalogowy
S/013
 Seat Toledo od 05 -> Seat Altea XL od 11/06 ->

Marka
 Seat Altea, Leon od 05/07 ->



96-111 Kowiesy, Chojnata 23 A
 tel. +48 46 831 73 31

- Odkręcić zderzak.
- Odkręcić belkę zderzeniową (nie będzie już wykorzystana).
- Udrożnić technologiczne otwory na bokach podłużnic (są zaślepione taśmą).
- Wsunąć elementy boczne belki zaczepu do podłużnic, przykręcić śrubami M10x35 8.8 (pkt 1).
- Wykonać wycięcie w dolnej części zderzaka o wymiarach 50x50.
- Dokręcić wszystkie śruby z momentem wg tabeli.
- Przykręcić zderzak.
- Przykręcić kulę i podstawę gniazda elektrycznego.
- Podłączyć instalację elektryczną.

- Unscrew the bumper.
- Unscrew the bumper bar (it will not be used any more).
- The holes on the sides of the metal clamps make permeable (these holes are stuck).
- Insert the side elements of the main bar in the metal clamps, screw with bolts M10x35 8.8 (point 1).
- Cut out the fragment measuring 50x50 in the lower part of the bumper.
- Tighten all the bolts according to the torque setting- see the table.
- Screw the bumper.
- Fix the ball and electric plate.
- Connect the electric wires.

- Démonter les lampes, la protection du seuil du coffre, le pare-chocs.
- Dévisser la poutre de chocs (elle ne sera plus utilisée).
- Insérer la poutre du crochet d'attelage A dans les trous dans les longerons et la serrer en utilisant les boulons M10x40 8.8 (point 1).
- Couper un trou 60x110 dans la partie inférieure du pare-chocs, environ 50 mm de son bord.
- Monter le pare-chocs.
- Serrer tous les boulons avec un couple de serrage selon tableau.
- Visser le crochet d'attelage et socle de prise électrique à l'aide des boulons M12x70 8.8 (point 2).
- Raccorder le circuit électrique.

