



RENAULT MASTER Van, Pick-Up
 OPEL MOVANO Van, Pick-Up
 NISSAN INTRASTAR Van, Pick-Up

1998 -
 1999 -
 09.2002 -

Cat. No. **R/009**

e20

e20*94/20*0274*00

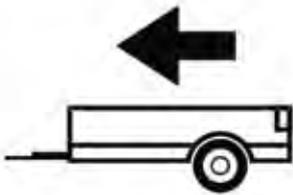

2300Kg



100Kg

D = 13,62kN

$$D \text{ (kN)} = \frac{\text{MAX kg} \times \text{MAX kg}}{\text{MAX kg} + \text{MAX kg}} \times 0,00981$$

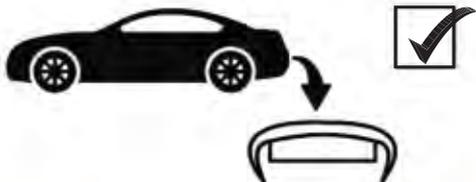

IMIOLA HAK-POL

96-111 KOWIESY, CHOJNATA 23A, POLAND

tel. +48 46 831 73 31, fax +48 831 74 29

e-mail: office@imiola.pl, www.imiola.pl

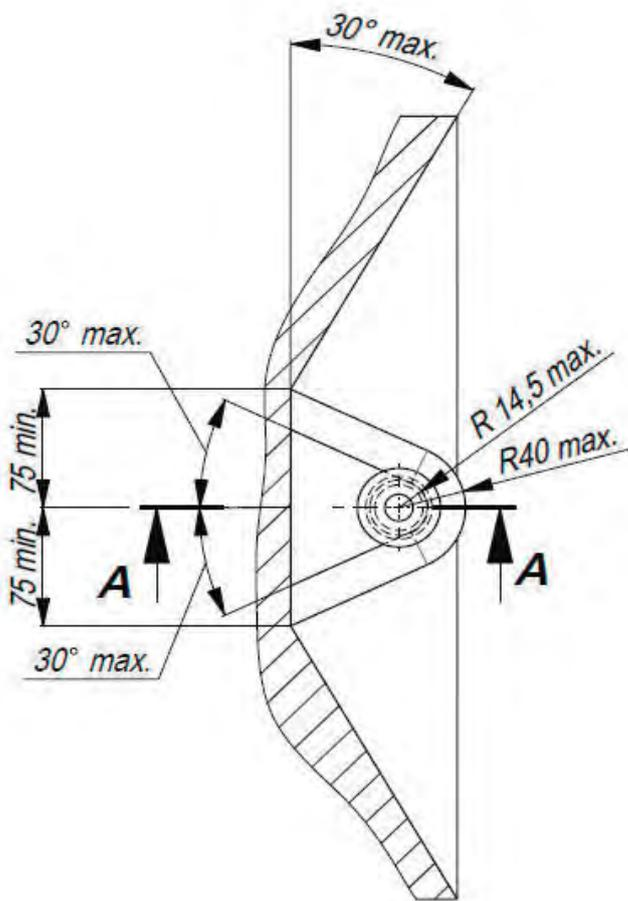

PRZEKRÓJ A-A

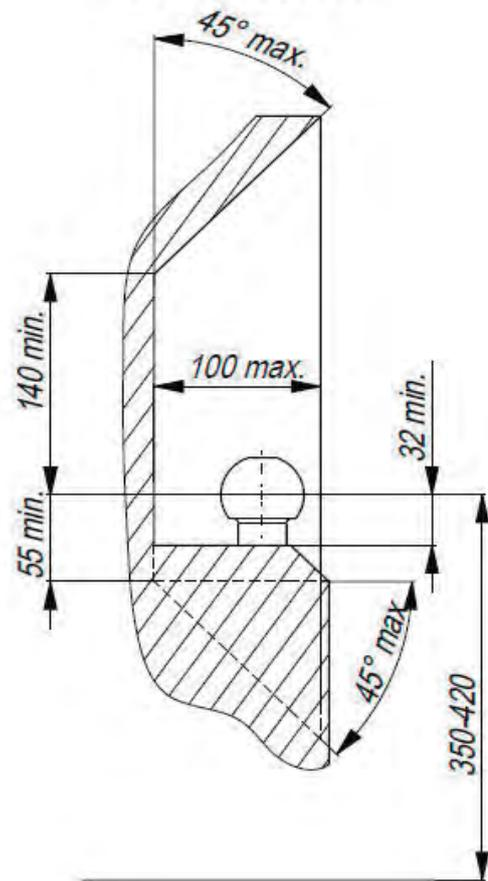

PL Należy zagwarantować przestrzeń swobodną według załącznika VII, rysunek 25a/b Regulaminu EKG ONZ 55.01 przy dopuszczalnym ciężarze całkowitym pojazdu.

GB The clearance specified in appendix VII, diagram 25a/b of Regulation No. 55.01 UN EU must be guaranteed at laden weight of the vehicle.

F L'espace libre doit être garanti conformément à l'annexe VII, illustration de la réglementation 55.01 CE pour un poids total en charge autorisé du véhicule.

D Der Freiraum nach Anhang VII, Abbildung 25a/b der Vorschriften 55.01 EG ist zu gew 25a/bahrleisten bei zulässigem Gesamtgewicht des Fahrzeuges

Moment skrecający dla śrub i nakrętek (8.8) Torque settings for nuts and bolts (8.8)	
M8	25Nm
M10	55Nm
M12	85Nm
M14	135Nm
M16	195Nm



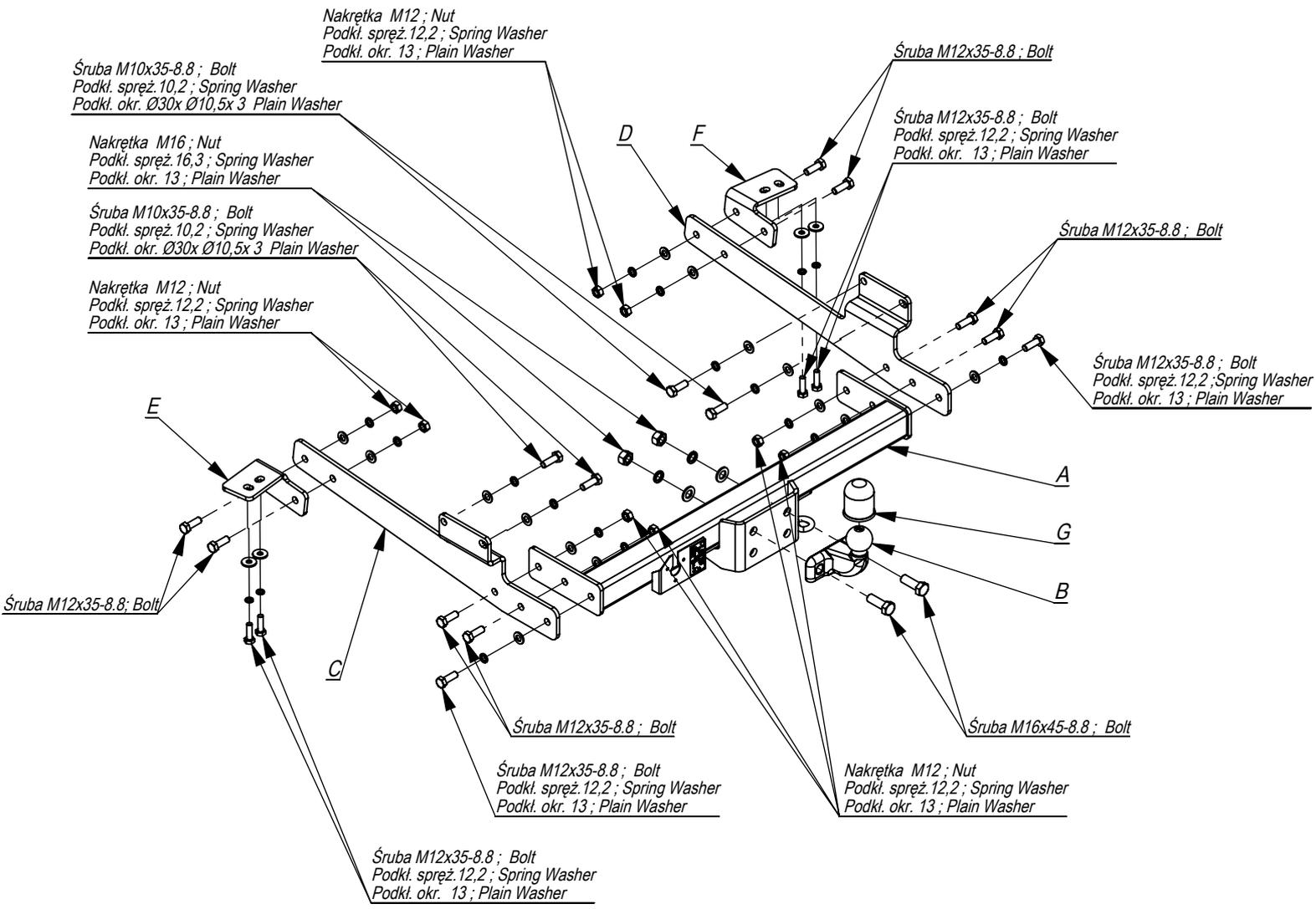

	A	x1		M16x45	2	
				M12x35	14	
				M10x35	4	
	B	x1		M16	2	
				M12	8	
	C	x1		Ø30xØ10,5x3	4	
					17	2
					13	14
	D	x1		10,5	4	
					16,3	2
					12,2	14
	E	x1		10,2	4	
					F	x1
	G	x1				

- Odkręcić koło zapasowe.
- W technologiczne punkty montażu zaczepu przykręcić lekko elementy zaczepu C i D śrubami M12x35 8.8 (pkt 2).
- Elementy E i F przykręcić od spodu do ramy śrubami M10x35 8.8 i skręcić z elementami C i D śrubami M12x35 8.8 (pkt 1 i 3).
- Przykręcić lekko belkę zaczepu A do elementów C i D śrubami M12x35 8.8 (pkt 4).
- Przykręcić kulę śrubami M16x45 8.8.
- Dokręcić wszystkie śruby z momentem siły wg tabeli.
- Podłączyć instalację elektryczną.
- Zamontować koło zapasowe.

- Unscrew the spare wheel.
- Screw slightly the elements C and D in the technological tow bar fitting points, with bolts M12x35 8.8 (point 2).
- Screw the elements E and F of the bottom to the chassis, with bolts M10x35 8.8 and screw to the elements C and D with bolts M12x35 8.8 (point 1 and 3).
- Screw slightly the main bar A to the elements C and D with bolts M12x35 8.8 (point 4).
- Fix the ball with bolts M16x45 8.8.
- Tighten all the bolts according to the torque setting- see the table.
- Connect the electric wires.
- Screw the spare wheel.

- Démonter la roue de secours.
- Serrez légèrement les éléments du crochet C et D par les boulons M12x35 8.8 (point 2) aux ouvertures de service.
- Serrez les éléments E et F par dessous au Cadre par les boulons M10x35 8.8 et ensuite serrez avec les éléments C et D par les boulons M12x35 8.8 (point 1 i 3).
- Serrez légèrement les socle du crochet A aux éléments C et D par les boulons M12x35 8.8 (point 4).
- Serrez la boule par les boulons M16x45 8.8.
- Serrer tous les boulons avec un couple de serrage selon tableau.
- Raccorder le circuit électrique.
- Monter la roue de secours.

