



1999 -

TOYOTA YARIS (C,E)

Cat. No. T/022

e20

e20\*94/20\*0751\*00

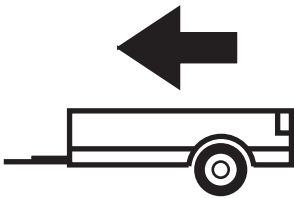

900Kg



50Kg

**D** = 5,37kN

D (kN) =



MAX kg

x

MAX kg

x 0,00981



MAX kg

+

MAX kg

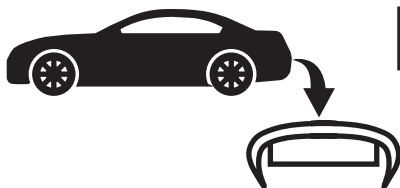

IMIOLA HAK-POL

96-111 KOWIESY, CHOJNATA 23A, POLAND

tel. +48 46 831 73 31, fax +48 831 74 29

e-mail: office@imiola.pl, www.imiola.pl

## PRZEKRÓJ A-A

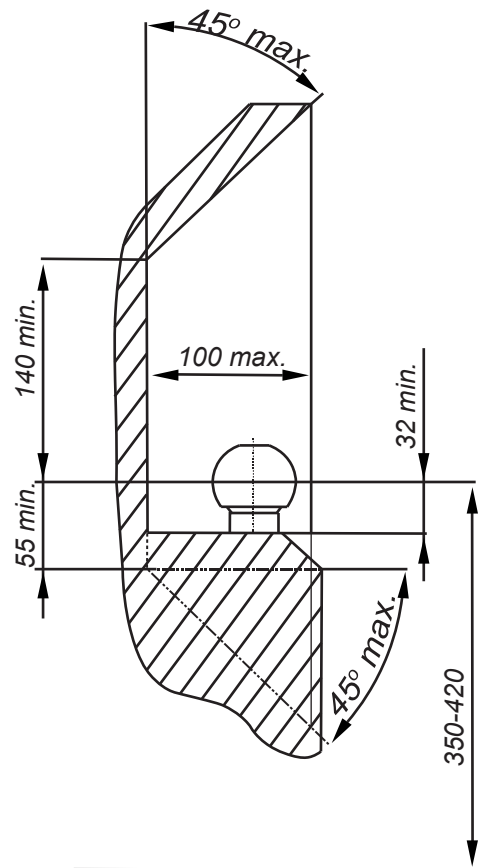
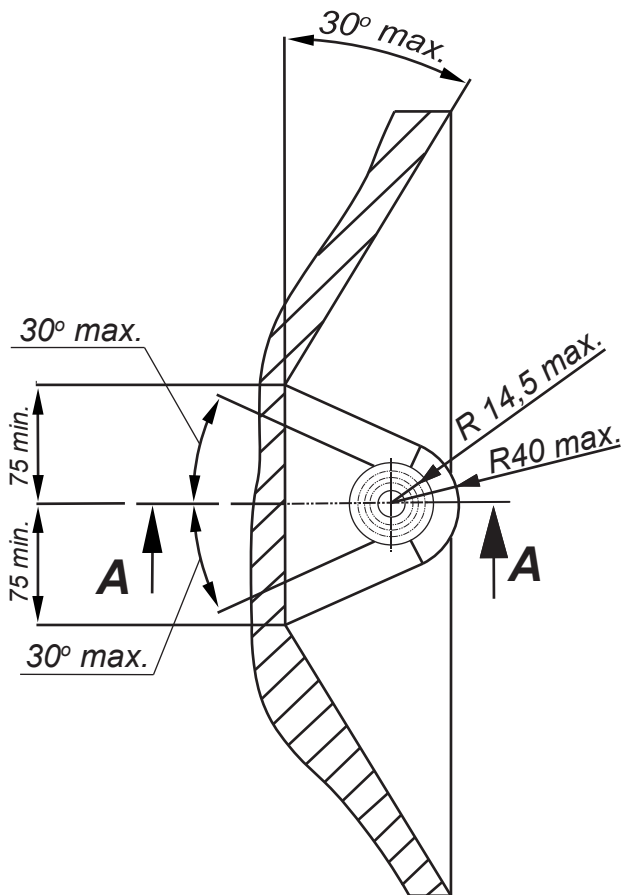

**PL** Należy zagwarantować przestrzeń swobodną według załącznika VII, rysunek 25a/b Regulaminu EKG ONZ 55.01 przy dopuszczalnym ciężarze całkowitym pojazdu.

**F** L'espace libre doit être garanti conformément à l'annexe VII, illustration de la réglementation 55.01 CE pour un poids total en charge autorisé du véhicule.







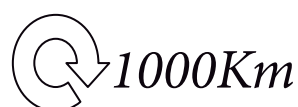

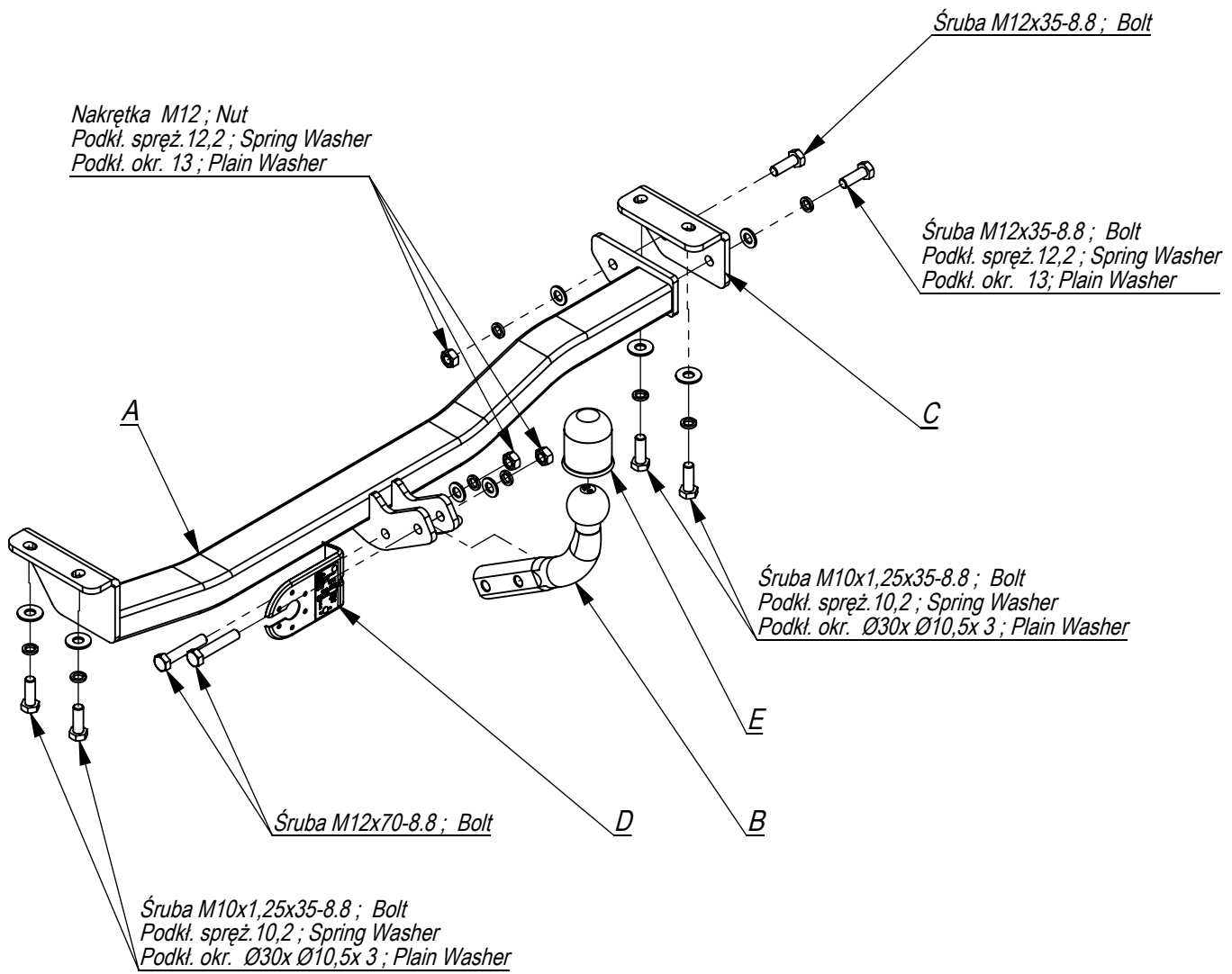

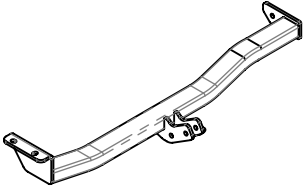
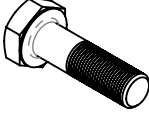
**GB** The clearance specified in appendix VII, diagram 25a/b of Regulation No. 55.01 UN EU must be guaranteed at laden weight of the vehicle.

**D** Der Freiraum nach Anhang VII, Abbildung 25a/b der Vorschriften 55.01 EG ist zu gewährleisten bei zulässigem Gesamtgewicht des Fahrzeuges.

Moment skręcący dla śrub i nakrętek (8.8) Torque settings for nuts and bolts (8.8)	
M8	25Nm
M10	55Nm
M12	85Nm
M14	135Nm
M16	195Nm





	A	x1		M12x70	2
				M12x35	2
				M10x1,25x35	4
	B	x1		M12	3
					Ø30xØ10,5x3
	C	x1		13	4
					12,2
	D	x1		10,2	4
					

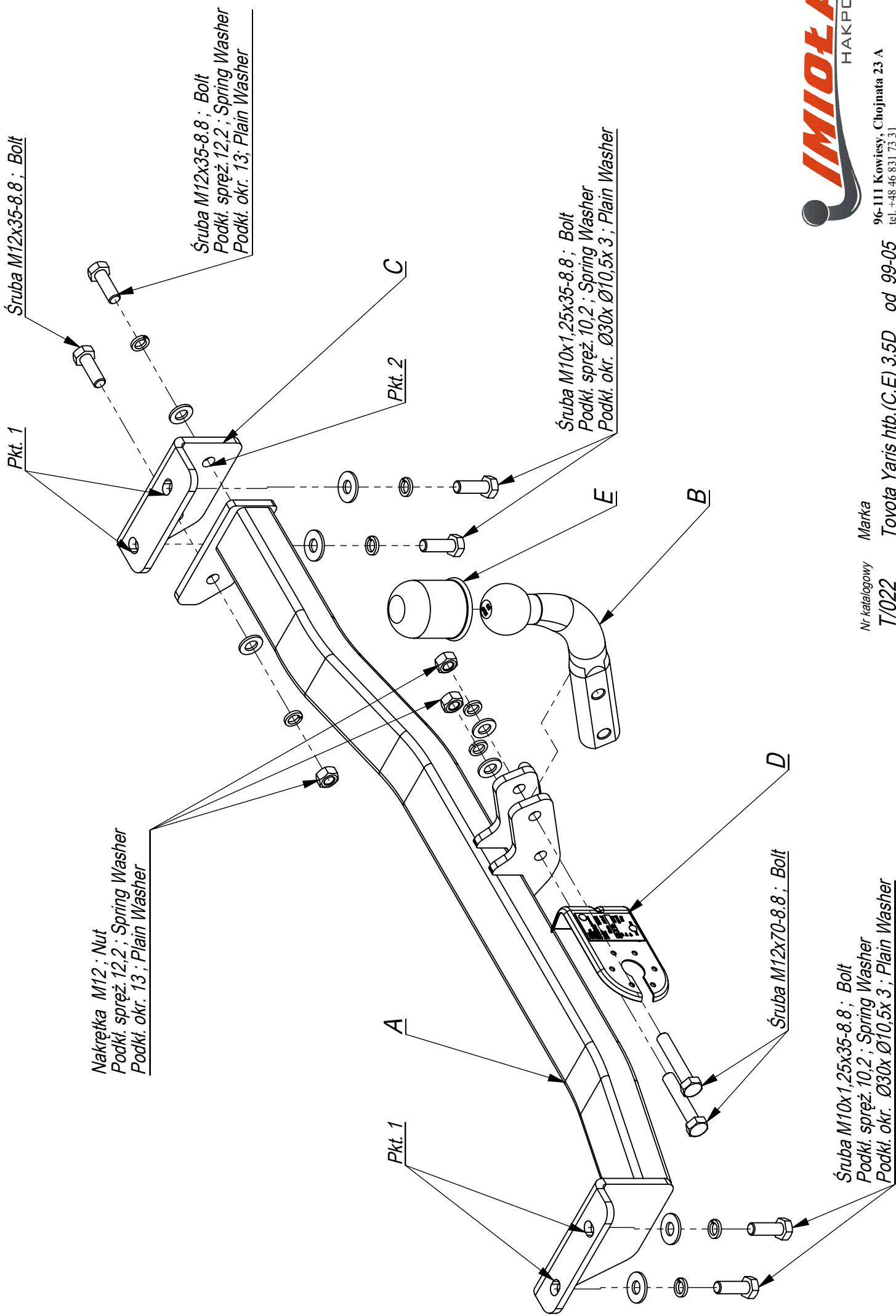

96-111 Kowiesy, Chojnata 23 A  
 tel. +48 46 831 73 31

Nr katalogowy: T/022  
 Marka: Toyota Yaris htb.(C,E) 3.5D od 99-05

Śruba M10x1,25x35-8.8 ; Bolt  
 Podkł. spręż. 10,2 ; Spring Washer  
 Podkł. okr. Ø30x Ø10,5x 3 ; Plain Washer

- Odkręcić ucha holownicze
- Przykręcić luźno belkę haka A i wspornik C w miejsca montażu uch holowniczych (pkt 1) oryginalnymi śrubami M10x35 8.8.
- Przykręcić luźno wspornik C do belki zaczepu A śrubami M12x35 8.8 (pkt 2).
- Podłączyć instalację elektryczną.
- Przykręcić kulę i podstawę gniazda elektrycznego.
- Dokręcić wszystkie śruby z momentem według tabeli.

- Unscrew the towing eyes.
- Screw slightly the main bar A and supporter C in the towing eyes fitting places (point 1), with original bolts M12x35 8.8.
- Screw slightly the supporter C to the main bar A with bolts M12x35 8.8 (point 2).
- Connect the electric wires.
- Fix the ball and electric plate.
- Tighten all the bolts according to the torque setting- see the table.

- Dévisser les anneaux d'attelage.
- Visser légèrement la poutre du crochet A et le support C au point de montage des anneaux d'attelage (point 1) avec des boulons originaux M10x35 8.8.
- Visser librement le support C a la poutre du crochet A avec des boulons M12x35 8.8 (point 2).
- Raccorder le circuit électrique.
- Visser le crochet d'attelage et socle de prise électrique.
- Serrer tous les boulons avec un couple de serrage selon tableau.

