



03/2013 -

VOLKSWAGEN TOURAN

Cat. No. **W/025**

e20

e20*94/20*0135*00

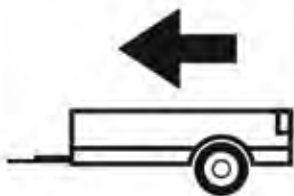

1825Kg



75Kg

D = 9,90kN

$$D \text{ (kN)} = \frac{\text{MAX kg} \times \text{MAX kg}}{\text{MAX kg} + \text{MAX kg}} \times 0,00981$$

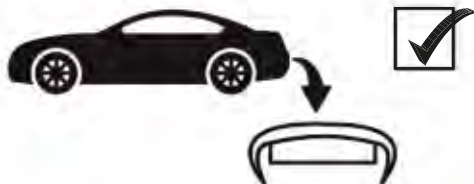

IMIOLA HAK-POL

96-111 KOWIESY, CHOJNATA 23A, POLAND

tel. +48 46 831 73 31, fax +48 831 74 29

e-mail: office@imiola.pl, www.imiola.pl

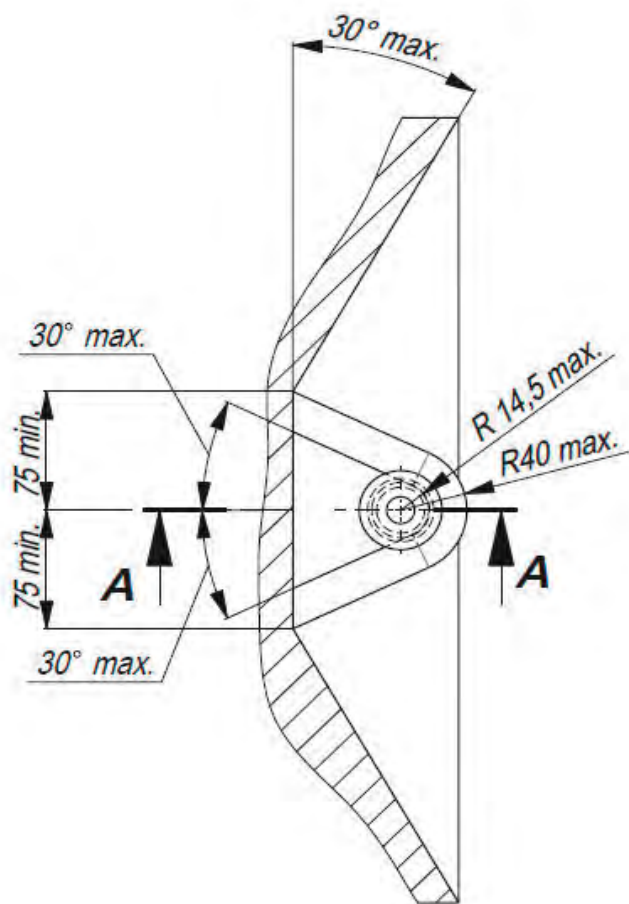

PRZEKRÓJ A-A

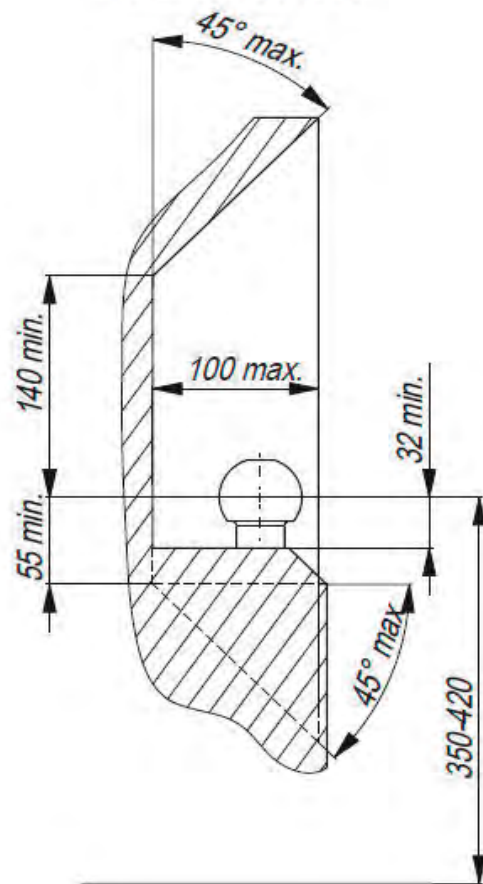

PL Należy zagwarantować przestrzeń swobodną według załącznika VII, rysunek 25a/b Regulaminu EKG ONZ 55.01 przy dopuszczalnym ciężarze całkowitym pojazdu.

GB The clearance specified in appendix VII, diagram 25a/b of Regulation No. 55.01 UN EU must be guaranteed at laden weight of the vehicle.

F L'espace libre doit être garanti conformément à l'annexe VII, illustration de la réglementation 55.01 CE pour un poids total en charge autorisé du véhicule.

D Der Freiraum nach Anhang VII, Abbildung 25a/b der Vorschriften 55.01 EG ist zu gew 25a/b abzuwehren bei zulässigem Gesamtgewicht des Fahrzeuges

Moment skrecający dla śrub i nakrętek (8.8)
Torque settings for nuts and bolts (8.8)

M8	25Nm
M10	55Nm
M12	85Nm
M14	135Nm
M16	195Nm



Šruba M10x40-8.8 ; Bolt
 Podkl. spręż. 10,2 ; Spring Washer
 Podkl. okr. Ø30x Ø10,5x 3 ; Plain Washer

Šruba M10x45-8.8 ; Bolt
 Podkl. spręż. 10,2 ; Spring Washer
 Podkl. okr. Ø30x Ø10,5x 3 ; Plain Washer

Šruba M12x40-8.8 ; Bolt
 Podkl. spręż. 12,2 ; Spring Washer
 Podkl. okr. 13 ; Plain Washer

Šruba M10x40-8.8 ; Bolt
 Podkl. spręż. 10,2 ; Spring Washer
 Podkl. okr. Ø30x Ø10,5x 3 ; Plain Washer







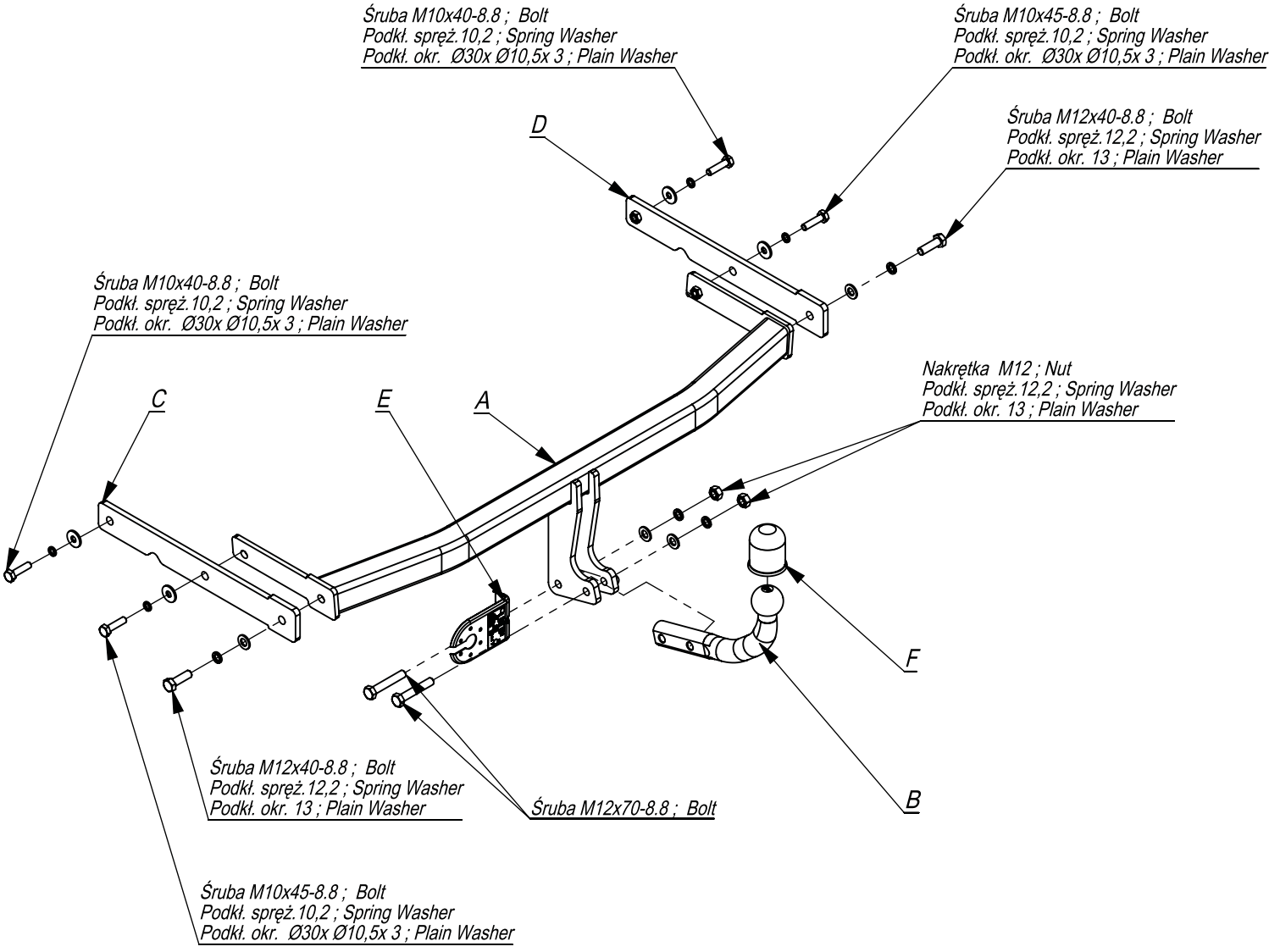

Nakrętka M12 ; Nut
 Podkl. spręż. 12,2 ; Spring Washer
 Podkl. okr. 13 ; Plain Washer

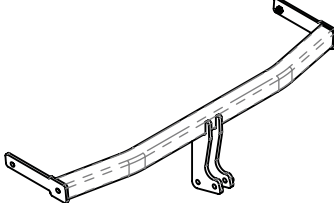
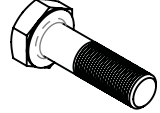
Šruba M12x40-8.8 ; Bolt
 Podkl. spręż. 12,2 ; Spring Washer
 Podkl. okr. 13 ; Plain Washer

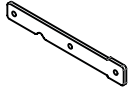
Šruba M12x70-8.8 ; Bolt

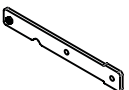
Šruba M10x45-8.8 ; Bolt
 Podkl. spręż. 10,2 ; Spring Washer
 Podkl. okr. Ø30x Ø10,5x 3 ; Plain Washer



	A	x1		M12x70	2
				M12x40	2
				M10x40	2
				M10x45	2
	B	x1		M12	2
	C	x1		Ø30xØ10,5x3	4
	D	x1			
	E	x1		13	4
				12,2	4
	F	x1		10,2	4

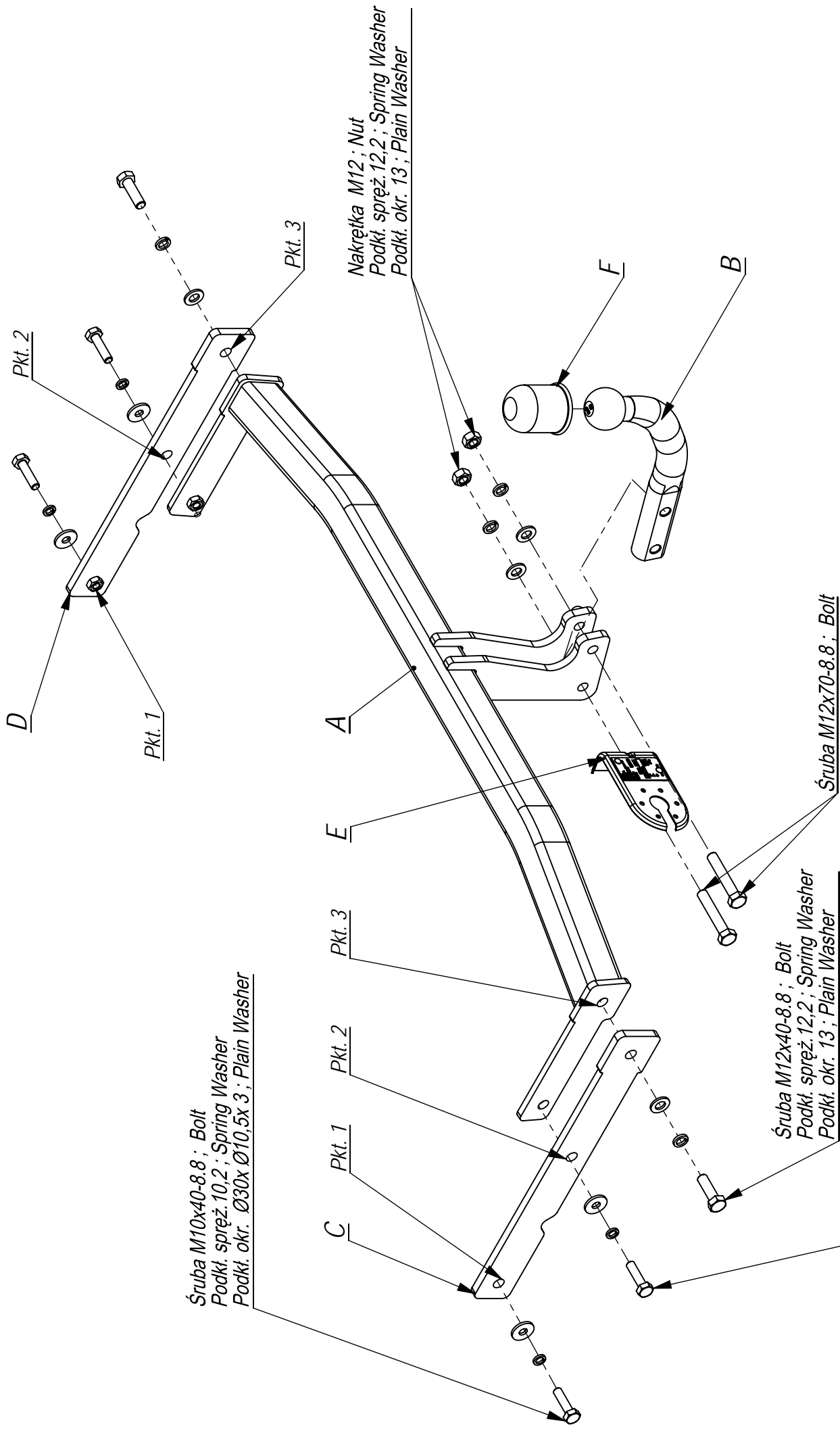

96-111 Kowiesy, Chojnata 23 A
tel. +48 46 831 73 31

Nr katalogowy W/025
Marka Volkswagen Touran od 03/03 ->

Śruba M10x40-8.8; Bolt
Podkl. spręż. 10,2; Spring Washer
Podkl. okr. Ø30x Ø10,5x 3; Plain Washer

Śruba M12x40-8.8; Bolt
Podkl. spręż. 12,2; Spring Washer
Podkl. okr. 13; Plain Washer

Śruba M12x70-8.8; Bolt

Nakrętka M12; Nut
Podkl. spręż. 12,2; Spring Washer
Podkl. okr. 13; Plain Washer

- Odkręcić zderzak.
- Od tylnego pasa samochodu odkręcić belkę zderzeniową (nie będzie już wykorzystana).
- W otwory podłużnic wsunąć elementy zaczepu C i D i poprzez technologiczne otwory w podłużnicy skręcić lekko śrubami M10x40 8.8 (pkt 1).
- Między elementy zaczepu C i D wsunąć do podłużnic belkę zaczepu A i poprzez technologiczne otwory w podłużnicy oraz otwory w elementach C i D (pkt 2) skręcić lekko śrubami M10x45 8.8.
- Skręcić elementy C i D z belką zaczepu A (pkt 3) śrubami M12x40 8.8.
- Dokręcić wszystkie śruby z momentem wg tabeli.
- Wykonać wycięcie w osi, w dolnej części zderzaka o wymiarach 100x50.
- Zamontować zderzak.
- Przykręcić kulę i blachę gniazda elektrycznego śrubami M12x70 8.8.
- Podłączyć instalację elektryczną.

- Disassemble the bumper.
- Unscrew the bumper bar from the rear belt of the car (it will not be used any more).
- Insert elements C and D in the holes of the metal clamps and screw slightly, through the technological holes in the metal clamps, with bolts M10x40 8.8 (point 1).
- Insert the main bar A between the elements C and D in the metal clamps and screw slightly, through the technological holes in the metal clamp and holes in the elements C and D (point 2), with bolts M10x45 8.8.
- Screw the elements C and D to the main bar A with bolts M12x40 8.8 (point 3).
- Tighten all the bolts according to the torque setting- see the table.
- Cut out the fragment 100x50 in the lower part of the bumper, in its axle.
- Assemble the bumper.
- Fix the ball and electric plate with bolts M12x70 8.8.
- Connect the electric wires.

- Serrer le pare-chocs.
- Dévisser la traverse de l'élément arrière (il ne sera plus utilisée).
- Introduire les éléments d'attache C et ensuite visser légèrement par les boulons M10x40 8.8 (point 1) à travers les ouvertures de longerons.
- Introduire la traverse d'attache A dans les longerons (entre les éléments d'attache C) et ensuite visser légèrement par les boulons M10x40 8.8 à travers les ouvertures de longerons et les ouvertures des éléments C (point 2).
- Visser les éléments C à la traverse d'attache A (point 3) par les boulons M12x35 8.8.
- Serrer tous les boulons avec un couple de serrage selon tableau.
- Ouvrir l'axe de pare-chocs en partie basse de 100x50.
- Poser le pare-chocs.
- Visser la boule et tôle de la prise électrique par les boulons M12x70 8.8.
- Raccorder le circuit électrique.

