



1998 - 2004

## FORD FOCUS com. I

Cat. No. E/025

e20

e20\*94/20\*1698\*00

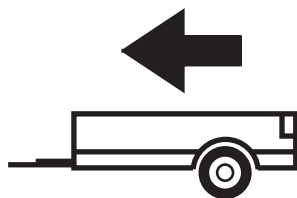

1400Kg



75Kg

**D** = 7,40kN

**D (kN) =**



MAX kg

x

MAX kg

x 0,00981



MAX kg

+

MAX kg



**IMIOLA HAK-POL**

96-111 KOWIESY, CHOJNATA 23A, POLAND

tel. +48 46 831 73 31, fax +48 831 74 29

e-mail: office@imiola.pl, www.imiola.pl

## PRZEKRÓJ A-A

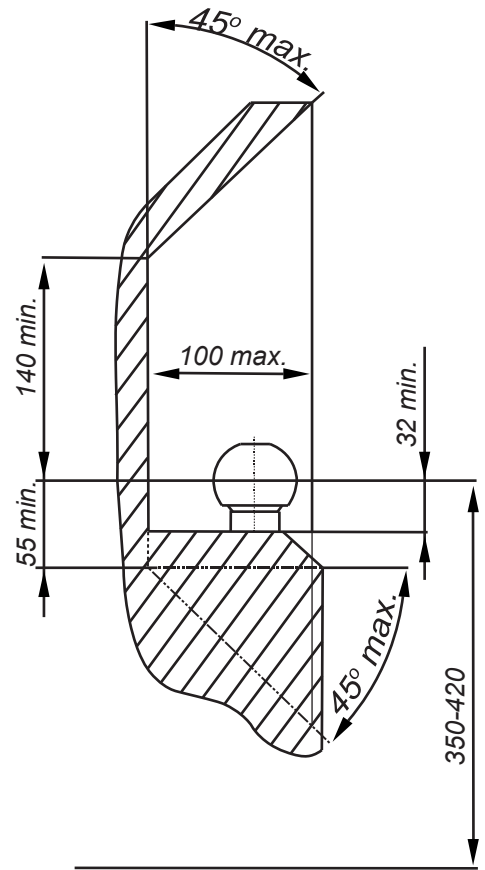
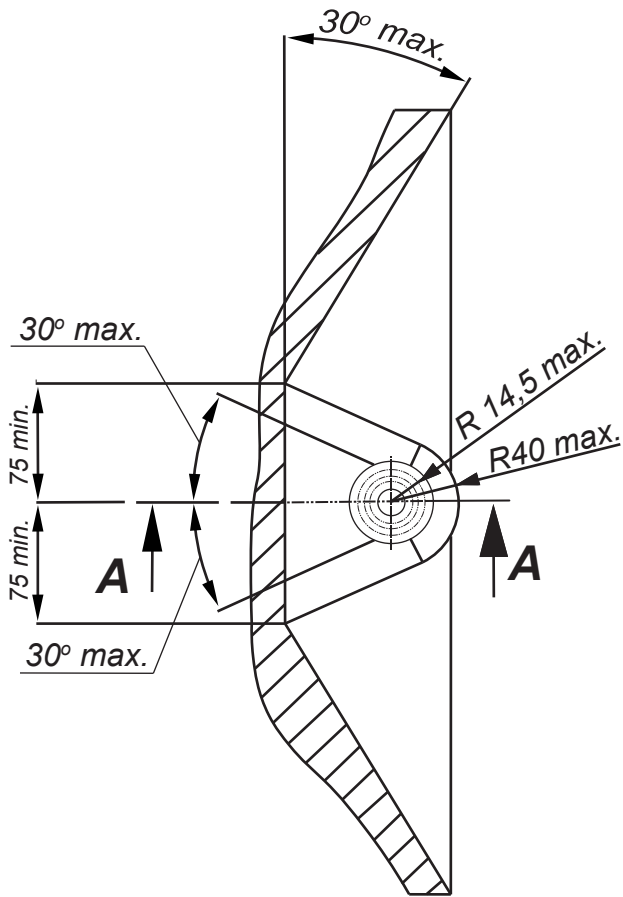

**PL** Należy zagwarantować przestrzeń swobodną według załącznika VII, rysunek 25a/b Regulaminu EKG ONZ 55.01 przy dopuszczalnym ciężarze całkowitym pojazdu.

**GB** The clearance specified in appendix VII, diagram 25a/b of Regulation No. 55.01 UN EU must be guaranteed at laden weight of the vehicle.







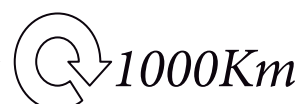

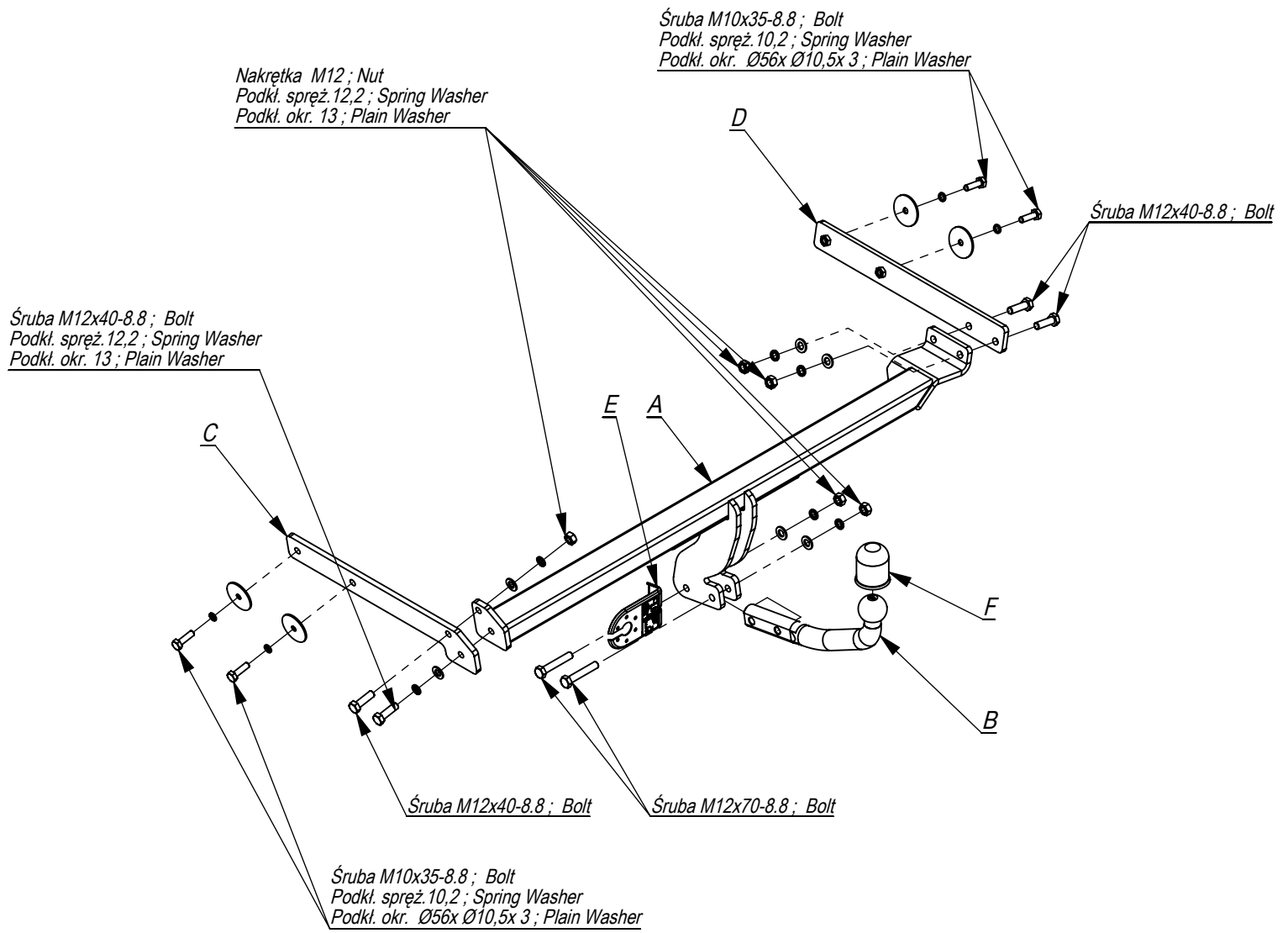
**F** L'espace libre doit être garanti conformément à l'annexe VII, illustration de la réglementation 55.01 CE pour un poids total en charge autorisé du véhicule.

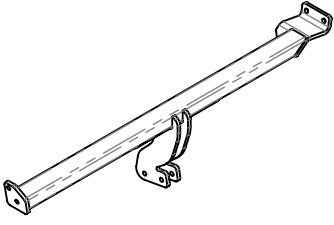
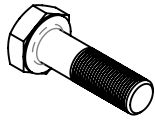
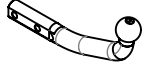
**D** Der Freiraum nach Anhang VII, Abbildung 25a/b der Vorschriften 55.01 EG ist zu gew 25a/b abzugeben bei zulässigem Gesamtgewicht des Fahrzeuges.

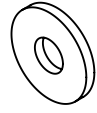
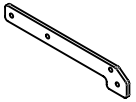
Moment skręcający dla śrub i nakrętek (8.8) Torque settings for nuts and bolts (8.8)	
M8	25Nm
M10	55Nm
M12	85Nm
M14	135Nm
M16	195Nm

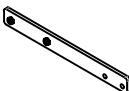



	A	x1		M12x70	2
				M12x40	4
				M10x35	4
	B	x1		M12	5
					Ø56xØ10,5x3
	C	x1		13	6
					13
	D	x1		13	6
				10,5	4
	E	x1		13	6
				10,5	4
	F	x1			

Nakrętka M12 ; Nut  
Podkł. spręż. 12,2 ; Spring Washer  
Podkł. okr. 13 ; Plain Washer

Śruba M10x35-8.8 ; Bolt  
Podkł. spręż. 10,2 ; Spring Washer  
Podkł. okr. Ø10,5x 3 ; Plain Washer

Pkt. 1

D

Śruba M12x40-8.8 ; Bolt

C

Pkt. 1

Śruba M12x40-8.8 ; Bolt  
Podkł. spręż. 12,2 ; Spring Washer  
Podkł. okr. 13 ; Plain Washer

Pkt. 2

A

E

Pkt. 2

F

B

Śruba M12x40-8.8 ; Bolt

Śruba M12x70-8.8 ; Bolt

Śruba M10x35-8.8 ; Bolt  
Podkł. spręż. 10,2 ; Spring Washer  
Podkł. okr. Ø10,5x 3 ; Plain Washer

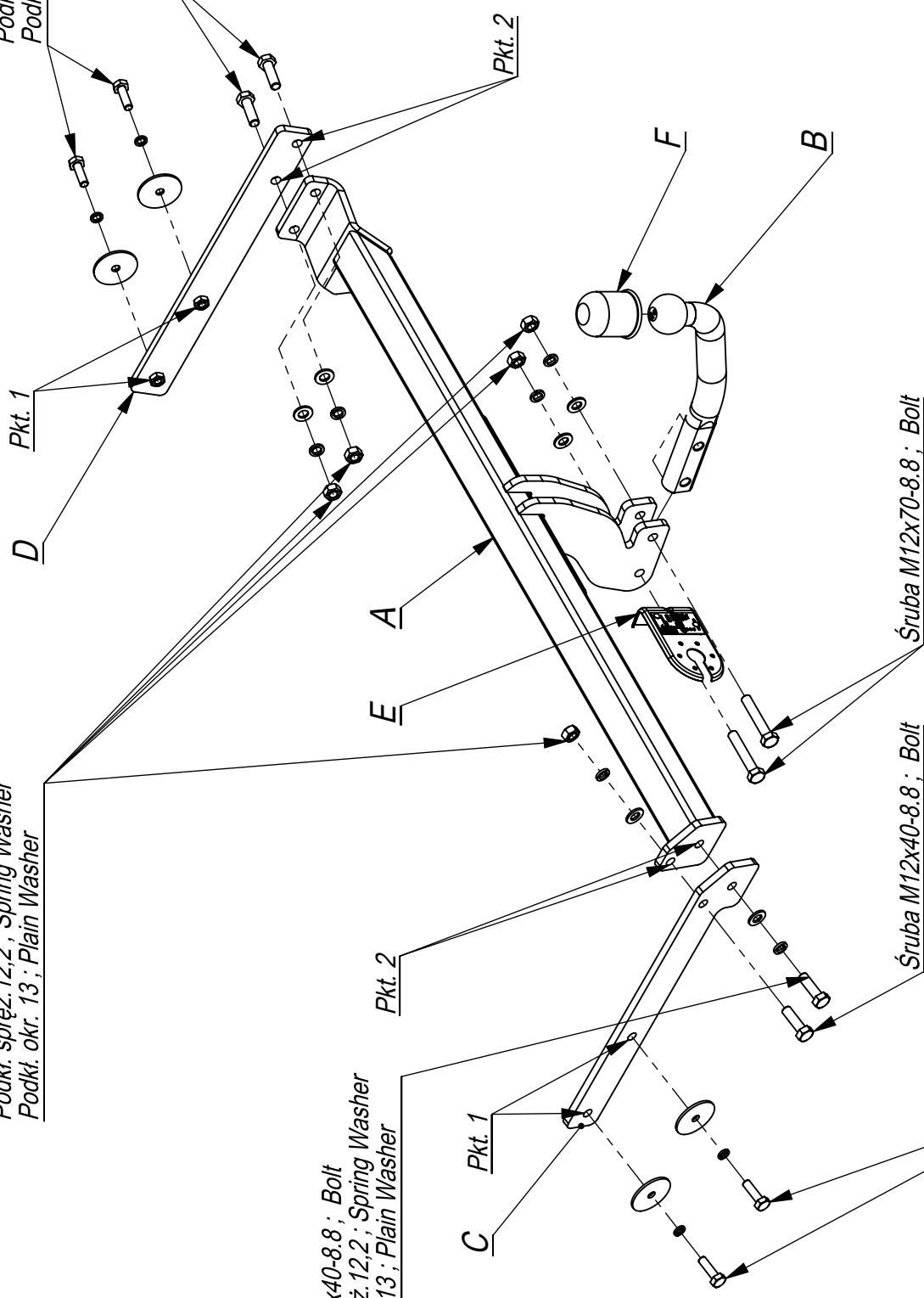

96-111 Kowiesy, Chojnata 23 A  
tel. +48 46 831 73 31

Nr katalogowy  
E/025

Marka  
Ford Focus combi od 98 ->

- Zdemontować zderzak. Udrożnić technologiczne otwory montażu zaczepu znajdujące się na zewnętrznych bokach podłużnic (pkt 1).
- Włożyć w podłużnice wsporniki zaczepu (wspornik C do lewej podłużnicy, wspornik D do prawej) i luźno przykręcić śrubami M10x35 8.8 (pkt 1) stosując podkładki F.
- Do wsporników C i D przykręcić lekko belkę zaczepu A śrubami M12x40 8.8 (pkt 2).
- W wypełnieniu zderzaka wyciąć fragment wg rys.
- Podłączyć instalację elektryczną.
- Wszystkie śruby dokręcić z momentem wg tabeli.
- Zamontować zderzak.
- Przykręcić kulę i blachę gniazda elektrycznego śrubami M12x70 8.8.

- Disassemble the bumper. The technological tow bar fitting holes on the external sides of the metal clamps make permeable (point 1).
- Insert the supporters in the metal clamps (the supporter C in the left metal clamp, D in the right) and screw slightly with bolts M10x35 8.8 (point 1) using washers F.
- Screw slightly the main bar A to the supporters C and D with bolts M12x40 8.8 (point 2).
- Cut out the fragment in the filling of the bumper, according to the drawing.
- Connect the electric wires.
- Tighten all the bolts according to the torque setting- see the table.
- Assemble the bumper.
- Fix the ball and electric plate with bolts M12x70 8.8

- Déposer le pare-chocs. Déboucher les ouvertures de crochet situées en externe des longerons (point 1).
- Insérer les consoles d'attache dans les longerons (la console C au longeron gauche, console D à celui de droit) et serrer légèrement avec les boulons M10x35 8.8 (point 1) et plaquettes F.
- Visser légèrement la traverse d'attache A aux consoles C et D par les boulons M12x35 8.8 (point 2).
- Serrer la traverse de crochet A à la partie arrière à travers les ouvertures en utilisant les éléments E selon croquis (point 3 et 4).
- Entreouvrir la pièce dans le garnissage de pare-chocs
- Raccorder le circuit électrique.
- Serrer tous les boulons avec un couple de serrage selon tableau.
- Poser le pare-chocs.
- Visser la boule et tôle de la prise électrique par les boulons M12x70 8.8.

