



1997-

RENAULT KANGOO

Cat. No. **R/006**

e20

e20\*94/20\*0463\*00

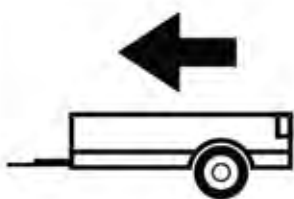

1350Kg



75Kg

**D = 7,73kN**

D (kN) =



MAX kg

x

MAX kg

x 0,00981



MAX kg

+

MAX kg



**IMIOLA HAK-POL**

96-111 KOWIESY, CHOJNATA 23A, POLAND

tel. +48 46 831 73 31, fax +48 831 74 29

e-mail: office@imiola.pl, www.imiola.pl

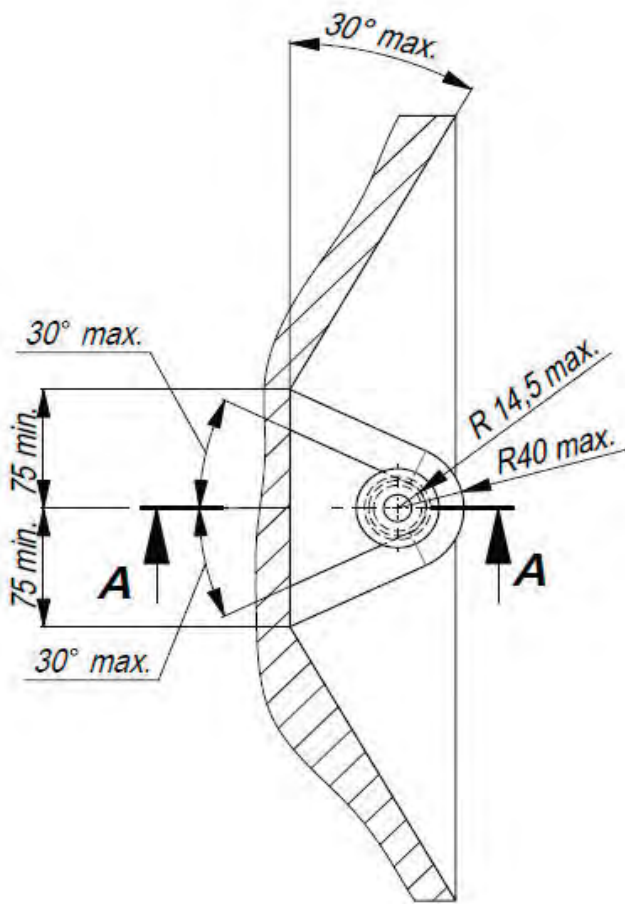

PRZEKRÓJ A-A

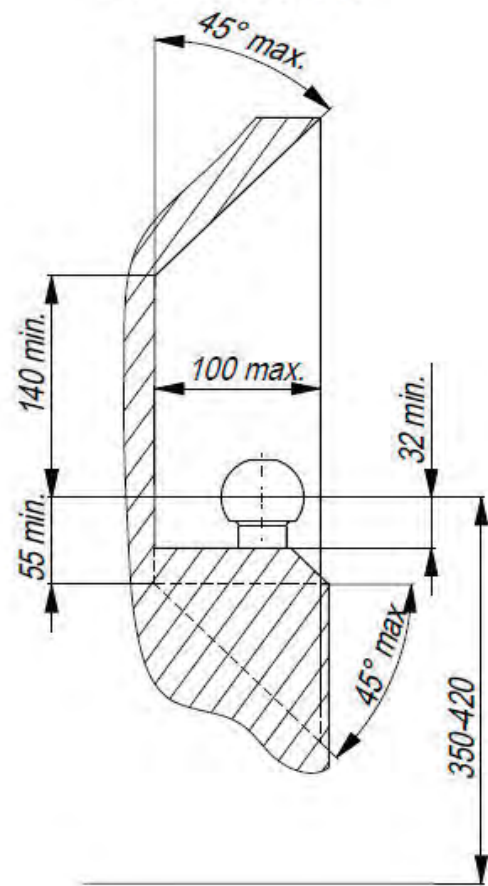

**PL** Należy zagwarantować przestrzeń swobodną według załącznika VII, rysunek 25a/b Regulaminu EKG ONZ 55.01 przy dopuszczalnym ciężarze całkowitym pojazdu.

**GB** The clearance specified in appendix VII, diagram 25a/b of Regulation No. 55.01 UN EU must be guaranteed at laden weight of the vehicle.

**F** L'espace libre doit être garanti conformément à l'annexe VII, illustration de la réglementation 55.01 CE pour un poids total en charge autorisé du véhicule.

**D** Der Freiraum nach Anhang VII, Abbildung 25a/b der Vorschriften 55.01 EG ist zu gew 25a/bahrleisten bei zulässigem Gesamtgewicht des Fahrzeuges

**Moment skręcający dla śrub i nakrętek (8.8)**  
**Torque settings for nuts and bolts (8.8)**

<b>M8</b>	<b>25Nm</b>
<b>M10</b>	<b>55Nm</b>
<b>M12</b>	<b>85Nm</b>
<b>M14</b>	<b>135Nm</b>
<b>M16</b>	<b>195Nm</b>

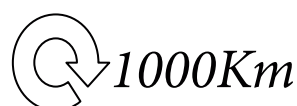

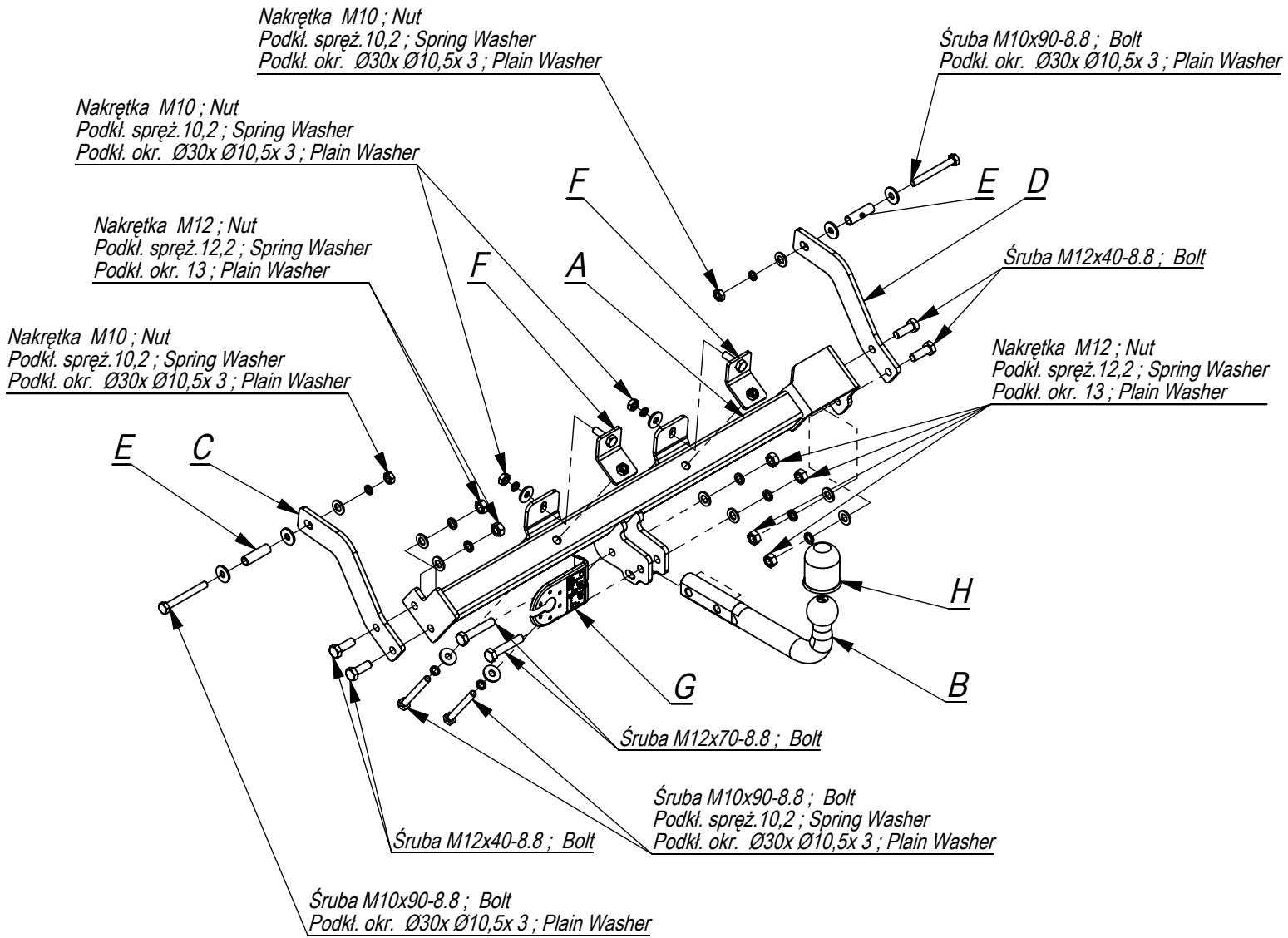

	A	x1		M12x70	2
				M12x40	4
				M10x90	4
	B	x1		M12	6
				M10	4
	C	x1		Ø30xØ10,5x3	8
	D	x1			
	E	x2		13	6
				F	x2
	G	x1		12,2	6
				10,2	6
	H	x1			

Śruba M10x90-8.8 ; Bolt  
Podkl. okr. Ø30x Ø10,5x 3 ; Plain Washer

Nakrętka M10 ; Nut  
Podkl. spręż. 10,2 ; Spring Washer  
Podkl. okr. Ø30x Ø10,5x 3 ; Plain Washer

Nakrętka M10 ; Nut  
Podkl. spręż. 10,2 ; Spring Washer  
Podkl. okr. Ø30x Ø10,5x 3 ; Plain Washer

Nakrętka M12 ; Nut  
Podkl. spręż. 12,2 ; Spring Washer  
Podkl. okr. 13 ; Plain Washer

Nakrętka M10 ; Nut  
Podkl. spręż. 10,2 ; Spring Washer  
Podkl. okr. Ø30x Ø10,5x 3 ; Plain Washer

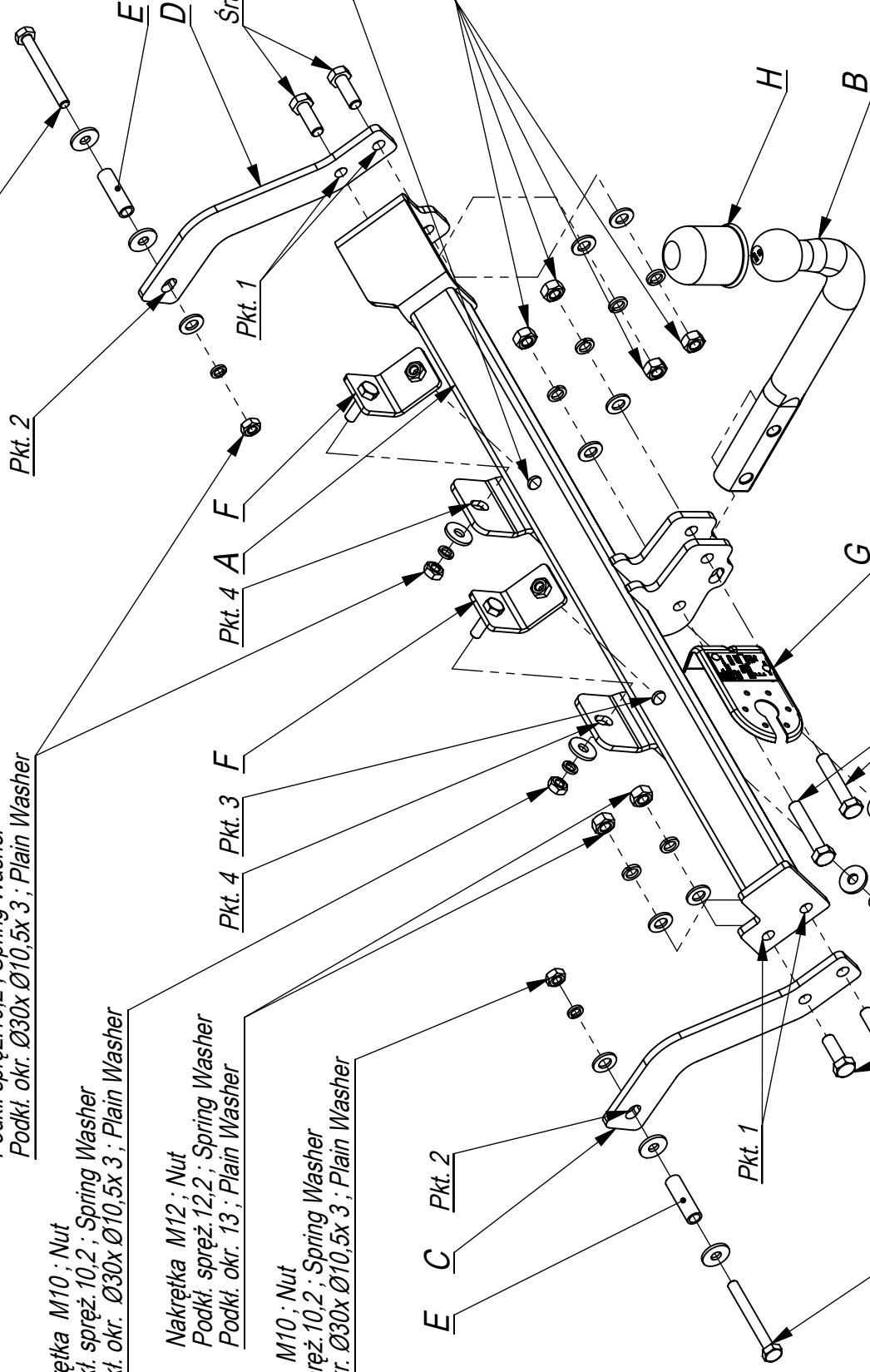

Śruba M12x35-8.8 ; Bolt

Nakrętka M12 ; Nut  
Podkl. spręż. 12,2 ; Spring Washer  
Podkl. okr. 13 ; Plain Washer

Śruba M12x70-8.8 ; Bolt

Śruba M10x90-8.8 ; Bolt  
Podkl. spręż. 10,2 ; Spring Washer  
Podkl. okr. Ø30x Ø10,5x 3 ; Plain Washer

Śruba M12x40-8.8 ; Bolt

Śruba M10x90-8.8 ; Bolt  
Podkl. okr. Ø30x Ø10,5x 3 ; Plain Washer



96-111 Kowiesy, Chojnata 23 A  
tel. +48 46 831 73 31

Nr katalogowy R/006  
Marka Renault Kangoo  
od 97-08

- Zdemontować koło zapasowe, opuścić tłumik z zawiesia.
- W fabryczne otwory w podłużnicy włożyć elementy E, a następnie element C i D przykręcić śrubami M10x90 8.8 (pkt. 2)
- Belkę haka A przyłożyć do tylnego pasa i przykręcić do elementów C i D śrubami M12x40 8.8 (pkt. 1) a następnie poprzez elementy F przykręcić do tylnego pasa śrubami M10x90 8.8 (pkt. 3,4)
- Przykręcić kulę i blachę gniazda elektrycznego.
- Dokręcić wszystkie śruby z momentem wg tabeli.
- Podłączyć instalację elektryczną.
- Zawiesić tłumik, zamontować koło zapasowe.

- Disassemble the spare wheel.
- Put the element F through the technological holes.
- Put the main bar of the tow bar to the rear belt at the bottom of car and next screw with bolts M10x90 8.8 (point 2) through the holes (point 3) and with nuts M10 through the holes (point 4) together with the supporters.
- Insert the sleeves E in the holes placed in the right and left metal clamps from the internal side.
- Put the elements C and D and screw through the holes and the sleeves with bolts M10x90 8.8 (point 2).
- Screw the elements C and D to the main bar through the holes with bolts M12x35 8.8 (point 1).
- Fix the ball and electric plate.
- Tighten all the bolts according to the torque setting- see the table.
- Connect the electric wires.
- Assemble the spare wheel.

- Enlever la roue de secours.
- Mettre le plat union (position 5) dans les ouvertures de l'ail arrière.
- Présenter la poutre principale du crochet (position 1) à l'ail arrière par dessous de la voiture, ensuite serrer avec les boulons M10x90mm (position 10) à travers les ouvertures (position A) et avec les écrous M10 à travers les ouvertures avec les renforts (position B).
- Mettre les douilles position 6 (coté interne) dans les ouvertures existantes des longerons coté droit et gauche.
- Présenter les renforts latéraux (position 4) à travers les ouvertures (position C); serrer les douilles avec les boulons M10x90mm (position 10) fournis dans kit.
- Serrer la poutre du crochet aux renforts latéraux à travers les ouvertures (position D) avec les boulons M12x35mm (position 9).
- Serrer la partie sphérique du crochet (position 2) avec tôle pour siège (position 3) au crochet ainsi préparé avec les boulons M12x70mm (position 7) et M12x70mm (position 8).
- Serrer tous les boulons avec couple de serrage suivant le tableau
- Raccorder les câbles de la prise 7-pôles au resau électrique suivant le mode d'emploi de fabricant de la voiture (ASO recommandé).
- Effectuer les retouches de peinture eventuelles du crochet suite au montage.

